

COMPLEX PATTERNS OF GENE DUPLICATION IN THE *APETALA3* AND *PISTILLATA* LINEAGES OF THE RANUNCULACEAE

Elena M. Kramer,^{1,*} Verónica S. Di Stilio,* and Philipp M. Schlüter^{2,†}

*Department of Organismic and Evolutionary Biology, Harvard University, Cambridge, Massachusetts 02138, U.S.A.; and

†Keble College, University of Oxford, Oxford OX1 3PG, United Kingdom

It has been proposed that the diversification of the MADS-box gene family of transcription factors has played a major role in the radiation of land plants. This suggestion is based on the critical roles that these genes play in plant development and the apparent coincidence of key duplication events with major radiations, such as the establishment of the B and C lineages concurrent with the evolution of the seed plants. On a more recent scale, it is also possible that subsequent duplication events have contributed to later morphological diversifications. In order to investigate this possibility, we are studying the evolution of homologs of the petal and stamen identity genes *APETALA3* (*AP3*) and *PISTILLATA* (*PI*) in the Ranunculaceae. In this family, the *AP3* and *PI* lineages have undergone many duplication events at every phylogenetic level. Early duplications gave rise to three paralogous *AP3* lineages, which are found throughout the family. In contrast, numerous duplications have occurred relatively recently in the *PI* lineage. We outline a hypothesis that these duplications have played a role in the evolution of the unique types of petaloid organs in the Ranunculaceae and present preliminary expression data supporting such a scenario.

Keywords: *APETALA3*, *PISTILLATA*, gene duplication, MADS-box genes, Ranunculaceae.

Introduction

It has been more than 30 yr now since Susumu Ohno's highly influential book *Gene Duplication in Evolution* (Ohno 1970) outlined the potential role of gene duplications as a force to drive the evolution of increasingly complex morphologies. Over the ensuing years, a large number of gene families have been identified, in large part confirming Ohno's vision while also expanding our understanding of the potential outcomes following gene duplication (reviewed in Otto and Yong 2002). Within the plant kingdom, particular attention has been given to the MADS-box gene family, the diversification of which appears to have played a role in the radiation of seed plants (Becker et al. 2000; Theissen et al. 2000). Members of this pan-eukaryotic family are characterized by the presence of a highly conserved domain of ca. 60 amino acids, which is involved in DNA binding and protein dimerization (Shore and Sharrocks 1995). In addition to the MADS domain, a large number of plant MADS-box genes display other conserved modules, adhering to what is known as the MIKC structure (Alvarez-Buylla et al. 2000). The I and K domains contribute to the ability of these proteins to dimerize and appear to influence the specificity of the dimerization interaction (Riechmann et al. 1996a, 1996b). Although the C-terminal portion

is quite variable, this region has recently been implicated as a mediator of ternary complex formation between dimers of MIKC-type proteins (Egea-Cortines et al. 1999). Consistent with this, many MADS-box gene lineages contain small, highly conserved motifs within their C domains (Kramer et al. 1998; Johansen et al. 2002).

The focus of comparative studies on the MADS-box genes has largely been the result of the critical roles that many members of the family play in developmental processes, particularly the ABC program of floral organ identity determination. The ABC model holds that organ identity is established by the overlapping functions of three classes of homeotic genes, known as A, B, and C (Coen and Meyerowitz 1991). The combinatorial functions of these gene classes result in specific organ identities: A coding for sepals; A+B, for petals; B+C, for stamens; and C alone, for carpels (fig. 1). Genetic analyses of mutations in A-, B-, and C-class genes from *Arabidopsis* and *Antirrhinum* indicate that this program is functioning similarly in both model species, despite their differences in floral morphology and the large phylogenetic distance that separates them (Carpenter and Coen 1990; Bowman et al. 1991). These mutants exhibit homeotic phenotypes, each displaying a transformation of floral organ identity in two adjacent whorls. In mutants in the B group genes, for instance, petals are transformed into sepals and stamens into carpels (Bowman et al. 1989). When the genes corresponding to the three classes of mutants were cloned, it was found that *Arabidopsis* genes from each class are homologous to those in the corresponding classes of *Antirrhinum* (Coen and Meyerowitz 1991). Furthermore, all but one of the ABC genes are members of the MADS-box family of transcription factors (reviewed in Theissen et al. 2000). In *Arabidopsis*, the A-group genes are represented by

¹ Author for correspondence; current address: 16 Divinity Avenue, Harvard University, Cambridge, Massachusetts 02138, U.S.A.; phone 617-496-3460; fax 617-496-5854; e-mail ekramer@oeb.harvard.edu.

² Current address: Department of Systematics and Evolution of Higher Plants, Institute of Botany, Rennweg 14, A-1030 Vienna, Austria.

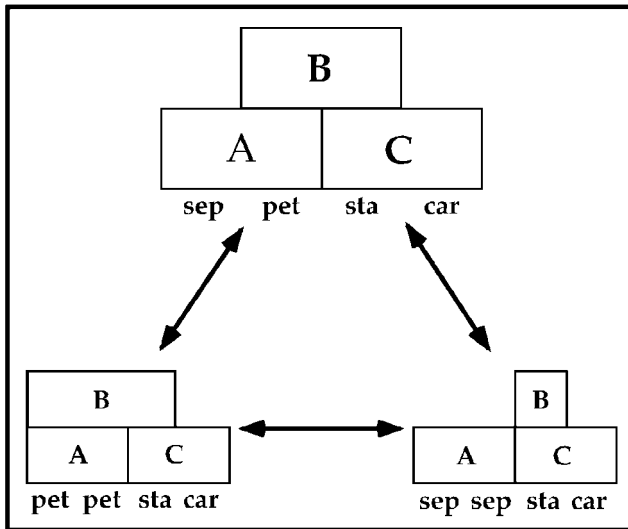

Fig. 1 Schematic showing the ABC model (top) with possible changes in domain boundaries and their predicted resultant floral phenotypes.

APETALA1 (*AP1*) and *APETALA2* (*AP2*, a non-MADS-box gene), the B-group genes by *APETALA3* (*AP3*) and *PISTILLATA* (*PI*), and the C-group genes by *AGAMOUS* (*AG*) (Coen and Meyerowitz 1991). These three classes have been expanded to include two other MADS-box gene lineages: the D class, which is involved in determining ovule identity (Angenent et al. 1995; Colombo et al. 1995), and the E class, which is critical to the formation of MADS-box protein complexes (Pelaz et al. 2000; Honma and Goto 2001). The E-class gene products, known in *Arabidopsis* as the SEPALLATAs, form dimers that interact with dimers of the ABC-class proteins, thereby providing the critical capability to activate transcription (Pelaz et al. 2000).

The elucidation of the ABC model has provided a compelling explanation for many aspects of floral diversity. In a series of elegant genetic experiments using both mutants and lines exhibiting ectopic expression of the ABC genes, it has been shown that the identities of all the floral organs in an *Arabidopsis* flower are interchangeable and depend entirely on the ABC code expressed in the developing primordia (Bowman et al. 1991; Mizukami and Ma 1992; Krizek and Meyerowitz 1996). For instance, ectopic expression of the *Arabidopsis* B-group genes results in the transformation of sepals into petals and the development of stamens in place of fourth-whorl carpels (Krizek and Meyerowitz 1996). These findings have major implications for the possible evolution of angiosperm perianth organs. One can imagine that if the evolution of the ABC program predated the radiation of extant angiosperms, the transition between an entirely petaloid perianth and one with sepals and petals could be due to an inward shift of the B domain boundary (fig. 1) (Bowman 1997; Albert et al. 1998). Similarly, a further inward shift would cause a lineage possessing petals to lose them, and, perhaps more importantly, an apetalous lineage could evolve petals by a simple outward shift of the B domain boundary. This “sliding-boundary” model represents a conflict between the Darwinian gradualism em-

braced by traditional botanical studies and our modern understanding of the power of homeosis to radically alter morphology. Moreover, it indicates that although the differences among types of petaloid organs seem to reflect independent derivation (Eames 1961; Bierhorst 1971; Takhtajan 1991), the pattern could be the product of a commonly inherited but differentially expressed petal identity program.

Broader studies have revealed both conservation and divergence in the ABC program (Gutierrez-Cortines and Davies 2000; Kramer and Irish 2000; Theissen et al. 2000). In particular, it has become clear that even within the angiosperms, gene-duplication events have resulted in modifications of the program (Mena et al. 1996; Kramer et al. 1998). For example, the ancestral *AP3* lineage, called the paleo*AP3* lineage, was duplicated at the base of the core eudicots to give rise to the paralogous eu*AP3* and *TM6* lineages, which each exhibit distinct patterns of sequence divergence (Kramer and Irish 2000). Despite such events, functional analyses of paleo*AP3* and *PI* homologs from the grasses *Oryza sativa* (rice) and *Zea mays* (corn) indicate a conservation of function in determining the identity of stamens and petal derivatives (Kang et al. 1998; Ambrose et al. 2000; Kyozuka et al. 2000; Ma and dePamphilis 2000). Studies in the more basal monocot *Lilium* demonstrate that while *AP3* and *PI* function as obligate heterodimers in *Arabidopsis* (Riechmann et al. 1996a), the *Lilium* homologs appear to have the capability to function as homodimers, although there is some conflicting evidence for the *AP3* homolog (Tzeng and Yang 2001; Winter et al. 2002). Taken together, such comparative analyses indicate that while the ABC program is generally conserved, it is not a static entity and may have changed in fairly significant ways over time, particularly in conjunction with gene-duplication events.

Simple modifications of the ABC model cannot explain all types of floral morphologies. One example is the production of distinctly different types of petaloid organs in separate whorls of the same flower, a phenomenon that occurs in a number of families including the Onagraceae, Passifloraceae, and, perhaps most notably, Ranunculaceae. In the Ranunculaceae, the first-whorl organs are typically petaloid but are referred to as sepals because of their position and many aspects of their development and morphology. In many genera of the family, the second whorl contains an additional type of petaloid organ. Although these petals are sterile, they bear a striking resemblance to stamens in all aspects of their development and, in several genera, their final appearance (Tamura 1965, 1981; Kosuge and Tamura 1989; Kosuge 1994). Across the family, a great variety of perianth morphologies is observed as a result of different combinations and elaborations of these two types of petaloid organs (fig. 2). In some genera, such as *Anemone*, only petaloid sepals are produced. In other genera, including *Helleborus* and *Aquilegia*, both types of petaloid organs are almost always present. Some genera have species representing both these morphologies, as exemplified by *Clematis* (Tamura 1965). In still other plants, the first-whorl organs are photosynthetic and the petals have a less staminoid appearance. Although this last type of perianth, found most notably in *Ranunculus*, resembles that of the core eudicots, these second-whorl petals are thought to share an ancestry with the staminoid, nectar-bearing petals found in species like *Helleborus* (Kosuge 1994; Erbar et al. 1998). It should be noted

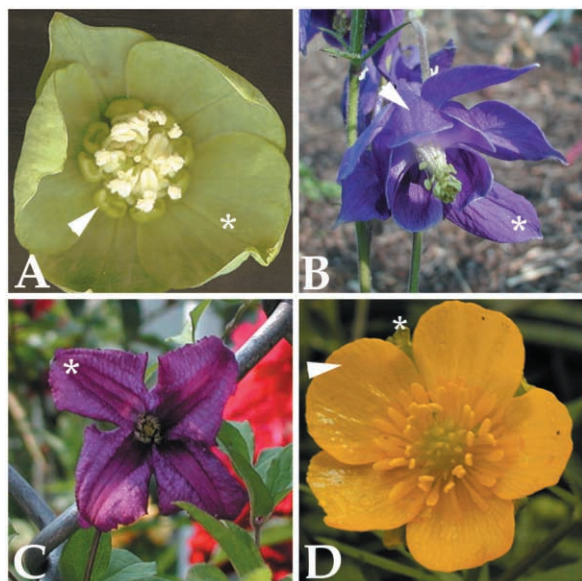

Fig. 2 A, *Helleborus foetidus*. B, *Aquilegia alpina*. C, *Clematis* sp. D, *Ranunculus acris*. Asterisks indicate sepals, which are petaloid in A–C; arrows indicate petals, which are absent in C.

that the phylogeny of the family is well established (Hoot 1995) and could be consistent with a single evolution of second-whorl petals, followed by several losses. Alternatively, petals may have arisen many times independently in parallel (Kosuge 1994).

We have initiated an investigation of the genetic basis for the distinct types of petaloid organs found in the Ranunculaceae. Specifically, we are seeking to understand how the underlying ABC program has been modified to produce separate petal identity programs within the same flower. As a starting point, we have characterized the *AP3* and *PI* lineage representatives from nine genera of Ranunculaceae and one genus each from Berberidaceae and Lardizabalaceae for outgroup comparison. This study has revealed complex patterns of gene duplication in both lineages, which may reflect trends of functional specialization and coevolution between *AP3* and *PI* paralogs. Preliminary characterization of gene expression patterns indicates that a particular *AP3* lineage may contribute to the distinction between types of petaloid organs.

Material and Methods

Cloning and Characterization

All of the taxa surveyed in this study are listed in table 1, along with voucher deposition or accession number information. The cloning and characterization of the *AP3* and *PI* homologs was performed using RT-PCR on floral RNA in a similar manner to that described in Kramer et al. (1998). The PCR primers used were as follows: forward, 5' AAYM-GRCARGTIACITAYCRAARMG; and reverse, 5' CCGGATC-CTCTAGAGCGGCCGC(T)₁₇. For each taxon, 100–220 clones of >700 bp were characterized using sequencing (ABI 3100 Genetic Analyzer) and/or restriction analysis. At least

five independent clones were sequenced for every identified locus. Specific RT-PCR of *AP3-III* orthologs was performed using the same forward primer as above with a reverse primer designed to a highly conserved motif in the C-terminal region of *AP3-III* orthologs. The sequence of this primer is 5' CCIT-CRTARTAIRGWWCYTCICCTC. A specific internal forward primer (see appendix in the online edition of *International Journal of Plant Sciences* [IJPS]) was used in combination with the poly-T primer to obtain the complete sequence of *ClcAP3-3* (see text).

Data Deposition and Phylogenetic Analysis

The nucleotide sequences of all new loci, including putative alleles and paleo*AP3* outgroup representatives, have been deposited in GenBank (accession numbers AY162835–AY162906). Other outgroup sequences used in the phylogenetic analyses have been previously reported in Kramer and Irish (1999).

Alignments of paleo*AP3* or *PI* nucleotide sequences were initially compiled using ClustalW, followed by hand adjustment based on amino acid sequence. Alignments are available in the online edition of *IJPS*. Phylogenetic analyses were conducted using PAUP* 4.0b1 (Swofford 2001). Fitch parsimony (MP) trees were generated with heuristic searches (1000 random stepwise additions and tree-bisection reconnection) with gaps treated as missing data. Bootstrap support for nodes was estimated with 1000 heuristic search replicates using the same setting as the original search. The paleo*AP3* data set was rooted with paleo*AP3* representatives from *Platanus occidentalis* (Arnold Arboretum accession number 111-58), while the *PI* data set was rooted with *PI* homologs from *Berberis gilgiana* and *Akebia quinata*. For both data sets, Wilcoxon sign-rank (Templeton 1983) and Kishino-Hasegawa (Kishino and Hasegawa 1989) tests were conducted to determine if the data could reject topologies that would indicate different patterns of gene duplication than those inferred from the MP tree.

RT-PCR Characterization of Expression

Differential expression of *AP3* and *PI* homologs in floral organs of *Aquilegia alpina*, *Aquilegia clematiflora* (a cultivar of *Aquilegia caerulea*; Munz 1946), and *Clematis integrifolia* was characterized using RT-PCR on total RNA prepared from dissected tissues. Organs were dissected from comparable stages of early buds, and total RNA was prepared using Trizol (Invitrogen, Carlsbad, Calif.). Each first-strand cDNA sample was synthesized from 5 μ g of total RNA using Superscript II reverse transcriptase (Invitrogen). Gene-specific primers were designed based on the known sequences from *A. alpina* and *C. integrifolia* (primer sequences are available in the online edition of *IJPS*). It was found that the gene-specific primers designed for *A. alpina* would also amplify orthologous loci in *A. clematiflora* (as confirmed by sequencing of the PCR fragments; GenBank accession numbers AY162853–AY162851; data not shown). This is not surprising given the recent diversification of the *Aquilegia* species group and their very high degree of nucleotide sequence similarity (1–2 nt differences/100 bps; Hodges and Arnold 1994). PCR reactions were carried out using 1.0 U of Platinum *Taq* DNA polymerase (Invitrogen) in 25 μ L of PCR buffer (20 mM Tris-HCl pH 8.4,

Table 1
APETALA3 and PISTILLATA Homologs Identified in This Study

Species	No. clones screened	Collection information	APETALA3	PISTILLATA
<i>Aquilegia alpina</i>	138	HUH EK117	<i>AqaAP3-1</i> (15), <i>AqaAP3-2</i> (27), <i>AqaAP3-3</i> (11)	<i>AqaPI</i> (29)
<i>Thalictrum thalictroides</i>	120	HUH VD101	<i>ThtAP3-1</i> (8), <i>ThtAP3-2a</i> (15), <i>ThtAP3-2b</i> (15)	<i>ThtPI</i> (22)
<i>Trollius laxus</i>	150	HUH EK120	<i>TllAP3-1*</i> (5), <i>TllAP3-2*</i> (6), <i>TllAP3-3*</i> (6)	<i>TllPI-1*</i> (25), <i>TllPI-2*</i> (17), <i>TllPI-3*</i> (18), <i>TllPI-4*</i> (10),
<i>Helleborus orientalis</i>	210	HUH EK118	<i>HoAP3-1</i> (5), <i>HoAP3-2</i> (5), <i>HoAP3-3a</i> (15), <i>HoAP3-3b</i> (6)	<i>HoPI-1</i> (24), <i>HoPI-2</i> (21), <i>HoPI-3</i> (7)
<i>Cimicifuga racemosa</i>	204	AA 472-93	<i>CirAP3-1</i> (21), <i>CirAP3-2</i> (17), <i>CirAP3-3</i> (7)	<i>CirPI-1</i> (16), <i>CirPI-2</i> (10), <i>CirPI-3*</i> (10)
<i>Anemone nemerosa</i>	220	HUH EK121	<i>AnnAP3-1</i> (6), <i>AnnAP3-2</i> (15), <i>AnnAP3-3*</i> (9)	<i>AnnPI-1*</i> (18), <i>AnnPI-2*</i> (15)
<i>Clematis integrifolia</i>	204	HUH EK119	<i>CliAP3-1</i> (7), <i>CliAP3-2</i> (24)	<i>CliPI-1</i> (10), <i>CliPI-2</i> (13)
<i>Trautvetteria carolinensis</i>	186	HUH EK116	<i>TrcAP3</i> (18)	<i>TrcPI-1</i> (18), <i>TrcPI-2</i> (10)
<i>Ranunculus ficaria</i>	144	HUH EK115	<i>RfAP3-1</i> (11), <i>RfAP3-2</i> (5), <i>RfAP3-3</i> (6)	<i>RfPI-1</i> (19), <i>RfPI-1b</i> (7), <i>RfPI-2</i> (5), <i>RfPI-3</i> (16)
<i>Berberis gilgiana</i>	164	AA 789-82	<i>BgAP3-1*</i> (7), <i>BgAP3-2</i> (8)	<i>BgPI-1</i> (6), <i>BgPI-2</i> (6)
<i>Akebia quinata</i>	150	AA 731-90, AA 2033-65	<i>AkqAP3-1*</i> (28), <i>AkqAP3-2*</i> (18)	<i>AkqPI*</i> (21)

Note. All genera are members of the Ranunculaceae with the exception of *Berberis gilgiana* and *Akebia quinata*, which are in the Berberidaceae and Lardizabalaceae, respectively. *Clematis chiisanensis* is not included in the table since a complete survey of this taxon has not been completed (see text). Gene names are based on the first letters of the genus and species names of each taxon. In some cases, when a particular initial had been already used for another taxon, the first two letters of the genus were combined with the first letter of the species. The number of clones screened indicates the total number of inserts greater than 700 bps that were analyzed by sequencing or restriction analysis. The collection information column shows either the number of the voucher, which is deposited in the Harvard University Herbarium (HUH), or the accession number of the living specimen at the Arnold Arboretum (AA). In every case, floral tissue was collected from single individuals, with the exception of the dioecious *Akebia*, in which male and female flower buds were collected from separate individuals. Homology to AP3 or PI is based on the presence of conserved motifs and phylogenetic analyses. Asterisks denote loci for which two alleles appear to have been recovered. The numbers in parentheses denote the number of independent clones sequenced for that locus. *RfAP3-1*, *RfAP3-2*, *RfPI-1*, and *RfPI-2* were previously reported in Kramer et al. 1998 and Kramer and Irish 1999.

50 mM KCl, 2.5 mM MgCl₂) containing 30 pmol of 5' and 3' primers, 200 μM of each dNTP, and 0.5 μL of cDNA. Amplification program was as follows: 95° for 12 min, followed by 25 cycles of 95° for 20 s, 50°–55° for 30 s, and 72° for 1 min; 20 μL of each reaction was run on a 1% agarose gel and digitally photographed. The identity of the amplified fragments was confirmed based on size and restriction analysis pattern for *A. alpina* and *C. integrifolia* and on sequencing for *A. clematiflora*.

Results

Analysis of the APETALA3 Lineage

Nine genera of the Ranunculaceae were surveyed, including further analysis of *Ranunculus ficaria*. From the floral cDNA of these genera, we characterized 23 new AP3 homologs (table 1). For four of these loci, two distinct but very similar cDNA sequences were recovered, which are most likely alleles based on their high degree of identity (94%–99% throughout). All loci display the diagnostic amino acid motifs typical of paleoAP3 lineage members (fig. 3). The one exception is *ThtAP3-2a* from *Thalictrum thalictroides*, which is truncated in the PI motif-derived region. *AnnAP3-3* from *Anemone nemerosa* also displays an unusual extension on its paleoAP3 motif region.

The nucleotide sequences of the 23 loci, in addition to those of paleoAP3 homologs from *Berberis gilgiana*, *Akebia quinata*, *Papaver nudicaule*, *Sanguinaria canadensis*, *Dicentra eximia*, and the non-Ranunculid lower eudicot *Platanus occidentalis* were aligned and analyzed under maximum parsimony. These analyses yielded two equally parsimonious trees of 3225 steps (fig. 4). In the consensus tree, the Ranunculaceae paleoAP3 representatives form three strongly supported lineages, which we have denoted AP3-I, AP3-II, and AP3-III. All of the genera from the Ranunculaceae were found to express AP3-I orthologs. *Trautvetteria carolinensis*, which is notable in that it lacks all petaloid organs, does not appear to express orthologs of AP3-II or -III. In both *T. thalictroides* and *Clematis integrifolia*, which have petaloid sepals but no true petals, expression of an AP3-III ortholog was not detected. Attempts to specifically amplify AP3-III orthologs from these three taxa also failed (data not shown; fig. 8B).

BgAP3-1 and *BgAP3-2* from *B. gilgiana* are associated with the AP3-III and AP3-II clades, respectively. These findings indicate that the AP3-II and AP3-III lineages were established before the common ancestor of the Ranunculaceae and Berberidaceae families. The position of the highly divergent paralog *PnAP3-1* from *P. nudicaule* is only marginally supported as sister to the AP3-III lineage. In parsimony analyses of an equivalent amino acid alignment, the resultant consensus tree is consistent with that in figure 4, with the exception that

		PI Motif-Derived										paleoAP3 Motif																					
<i>RbAP3-1</i>	P Q V	F	S	F	R	L	Q	P	S	-	Q	P	N	L	H	D	D	E	E	-	-	Y	E	I	H	D	L	R	L	V	-	-	
<i>RfAP3-1</i>	- - V	F	S	F	R	L	Q	P	S	-	Q	P	N	L	H	N	D	E	E	-	-	Y	E	I	H	D	L	R	L	A	-	-	
<i>TrcAP3</i>	P H I	Y	S	F	R	L	H	P	S	-	Q	P	N	L	H	E	D	E	E	-	-	Y	E	I	H	G	L	R	L	A	-	-	
<i>CltAP3-1</i>	S H I	F	A	F	R	L	H	P	G	-	Q	P	H	V	H	G	D	E	G	D	-	Y	D	F	H	Q	L	R	L	A	-	-	
<i>AnnAP3-1</i>	S H I	F	A	F	R	M	H	P	G	-	H	Q	D	V	H	G	D	-	-	-	-	Y	D	F	H	Q	L	R	L	A	-	-	
<i>HoAP3-1</i>	A H V	F	A	F	R	-	-	-	-	N	P	Y	-	E	A	D	K	A	G	-	Y	D	L	S	D	L	R	S	G	-	-		
<i>TllAP3-1</i>	S H M	F	G	F	R	L	Q	P	S	-	Q	P	N	L	H	D	D	G	G	A	-	Y	G	L	H	D	L	R	L	G	-	-	
<i>CirAP3-1</i>	S H V	F	M	F	R	L	Q	P	S	-	Q	P	N	L	R	D	D	G	G	-	-	Y	G	I	H	D	L	R	L	G	-	-	
<i>AqaAP3-1</i>	S H I	F	A	F	R	L	Q	P	S	-	Q	P	N	L	H	G	D	G	G	-	-	C	G	F	E	D	L	R	L	G	-	-	
<i>ThtAP3-1</i>	S H I	F	S	F	R	L	Q	P	S	-	Q	P	N	L	H	G	D	G	G	-	-	F	G	F	E	D	L	R	L	G	-	-	
<i>RbAP3-2</i>	S R I	Y	A	I	Q	M	Q	-	S	-	H	-	-	-	Q	D	A	Q	D	-	-	Y	G	S	Y	S	L	R	L	A	-	-	
<i>RfAP3-2</i>	S R I	Y	A	I	H	M	Q	-	T	-	H	-	-	-	Q	N	G	E	D	-	-	Y	G	S	Y	G	L	S	L	A	-	-	
<i>CltAP3-2</i>	S Q V	F	A	F	R	L	Q	P	T	-	Q	P	S	L	Q	D	A	Q	A	A	-	Y	G	S	Y	G	L	T	L	A	-	-	
<i>AnnAP3-2</i>	S Q V	F	A	F	R	L	Q	P	A	-	Q	H	S	L	Q	D	A	E	A	A	-	Y	G	S	Y	G	L	T	L	A	-	-	
<i>HoAP3-2</i>	S H I	F	A	F	R	L	Q	P	S	-	Q	A	N	I	Q	D	E	E	-	-	Y	D	P	Y	S	L	S	L	A	-	-		
<i>TllAP3-2</i>	A H I	F	A	F	R	L	Q	P	S	-	Q	P	N	L	H	L	Q	D	D	A	S	G	Y	G	S	Y	G	L	S	L	A	-	-
<i>CirAP3-2</i>	P H I	F	S	I	R	L	Q	P	S	-	Q	P	N	L	R	D	D	E	G	-	-	Y	A	S	Y	G	L	R	L	A	-	-	
<i>AqaAP3-2</i>	P Q I	F	A	F	R	L	Q	P	K	L	Q	S	D	L	Q	D	E	E	A	-	-	Y	G	S	Y	G	L	S	L	A	-	-	
<i>ThtAP3-2a</i>	P H I	F	A	F	G	L	Q	P	Q	L	-	-	-	-	-	-	-	-	-	-	-	-	-	-	-	-	-	-	-	-	-	-	
<i>ThtAP3-2b</i>	P Q I	F	A	V	R	W	Q	P	K	L	Q	S	N	I	Q	D	K	E	A	-	-	Y	G	S	Y	G	L	S	L	V	-	-	
<i>BgAP3-2</i>	S H E	F	A	F	G	L	Q	P	S	-	T	P	N	L	Q	D	G	R	G	-	-	Y	G	S	Y	D	F	H	L	D	-	-	
<i>RfAP3-3</i>	A H F	L	P	Y	G	L	H	P	G	-	Q	P	D	H	H	D	G	D	G	-	-	Y	A	L	H	N	L	R	L	A	-	-	
<i>AnnAP3-3</i>	E D F	V	A	Y	Q	L	Q	P	-	-	-	N	M	Q	E	V	E	D	-	-	F	G	L	Y	G	F	Q	L	A	Q	P	N	
<i>ClcAP3-3</i>	A H L	F	S	Y	H	L	Q	P	-	-	-	N	P	Q	E	V	E	A	-	-	H	G	A	C	D	F	H	L	A	-	-		
<i>HoAP3-3a</i>	E H I	L	S	Y	R	L	Q	P	S	-	E	A	N	L	Q	D	A	E	C	-	-	Y	G	S	Y	N	L	Q	L	A	-	-	
<i>HoAP3-3b</i>	A H I	L	S	Y	R	L	Q	P	N	-	R	G	N	L	P	D	A	D	G	-	-	Y	G	S	S	L	Q	L	A	-	-		
<i>TllAP3-3</i>	A H L	L	S	Y	R	L	Q	P	N	-	Q	P	N	L	Q	E	E	G	-	-	Y	G	S	Y	N	L	R	L	A	-	-		
<i>CirAP3-3</i>	A H L	L	P	Y	R	L	Q	P	S	-	Q	P	N	L	Q	D	G	E	N	-	-	Y	G	S	Y	N	L	R	L	G	-	-	
<i>AqaAP3-3</i>	A H L	V	S	Y	R	V	Q	P	S	-	Q	H	N	I	Q	N	G	E	G	-	-	Y	G	S	H	N	L	R	L	A	-	-	
<i>BgAP3-1</i>	- - L	Y	D	Y	R	L	Q	L	N	-	Q	P	N	L	R	-	G	E	G	-	-	F	Q	E	Y	F	G	V	M	H	-	-	
<i>AkqAP3-1</i>	S H I	F	A	L	R	L	Q	P	S	-	Q	P	I	L	R	E	G	G	G	-	-	Y	G	S	H	D	L	R	L	A	-	-	
<i>AkqAP3-2</i>	S H	F	A	F	R	L	Q	N	-	Q	P	N	L	Q	S	G	G	E	-	-	F	G	M	N	D	L	R	L	A	-	-		
<i>PnAP3-1</i>	S Q I	T	-	F	Q	L	Q	P	S	-	Q	P	N	L	H	H	A	A	G	G	G	Y	-	F	Y	S	Q	H	Y	A	-	-	
<i>PnAP3-2</i>	P N I	F	A	F	R	L	Q	P	S	-	Q	P	N	L	H	N	G	G	G	-	-	Y	N	C	H	D	L	R	L	A	-	-	
<i>ScAP3</i>	P N I	F	A	F	R	L	Q	P	S	-	Q	P	N	L	H	D	G	-	-	-	-	Y	S	S	N	D	L	R	L	A	-	-	
<i>DeAP3</i>	Q N I	F	A	F	R	L	Q	P	S	-	Q	P	N	L	H	D	G	G	G	-	-	Y	G	S	H	D	L	R	L	A	-	-	

Fig. 3 Alignment of the C termini of predicted protein sequences from all identified Ranunculid paleoAP3 homologs. Genes from the Ranunculaceae and Berberidaceae are grouped according to lineage as determined by phylogenetic analysis (see fig. 4). The PI motif-derived and paleoAP3 motifs are indicated with boxes. Residues in each region that show chemical conservation with the PI or paleoAP3 motif consensus sequences (Kramer and Irish 2000) are shaded.

PnAP3-1 falls as sister to the *AP3-I* lineage (data not shown). Analyses of the nucleotide data set using both Templeton and Kishino-Hasegawa tests show that this topology is not significantly different from the most parsimonious trees ($P = 0.5131$ and 0.6636 , respectively). In addition, a topology in which *AP3-I* and *-III* are sister lineages with *PnAP3-1* as the sister to both (as shown in fig. 4 inset *a*) is also not significantly different, with $P = 0.37$ for the Templeton test and 0.50 for Kishino-Hasegawa. Any sister relationships between *PnAP3-1* and the *AP3-II* lineage or between *PnAP3-1* and the other paleoAP3s from the Papaverales are found to be significantly different under both tests ($P < 0.001$). Although the nodes indicating the relationships of the *AP3-I*, *-II*, and *-III* lineages have less than 50% bootstrap support, trees in which *AP3-I* and *-II* or *AP3-II* and *AP3-III* are paired as sister lineages are more than 20 steps longer than the most parsimonious tree and are significantly different under both Templeton and Kishino-Hasegawa tests ($P < 0.05$).

The exact relationship between the three main lineages and the paleoAP3 homologs from the Papaverales and *Akebia* also

has little bootstrap support. Trees in which either *Akebia* homolog is placed as sister to the *AP3-I* or *-III* lineage are significantly different than the most parsimonious tree ($P < 0.001$ for both tests). However, a tree in which the whole clade of paleoAP3 representatives from *Akebia* and the Papaverales is sister to *AP3-II* (as shown in fig. 4 inset *b*) is 15 steps longer than the most parsimonious tree. This difference is significant using a Templeton test ($P = 0.04$) but is nonsignificant using a Kishino-Hasegawa test ($P = 0.052$). Taken together, these findings clearly show that three *AP3* lineages had been fixed before the diversification of the Ranunculaceae. At least two of these, and most likely all three, were established before the split of Ranunculaceae and Berberidaceae. It seems most plausible that *AP3-I* and *-III* are sister lineages. It is also possible that the duplication that produced the *AP3-III/II* and *AP3-II* lineages predated the diversification of the Ranunculids. Further sampling will be required to clearly establish the timing of these duplication events.

Within each of the three major lineages, little or no support is found for the resolution of generic relationships. Supported

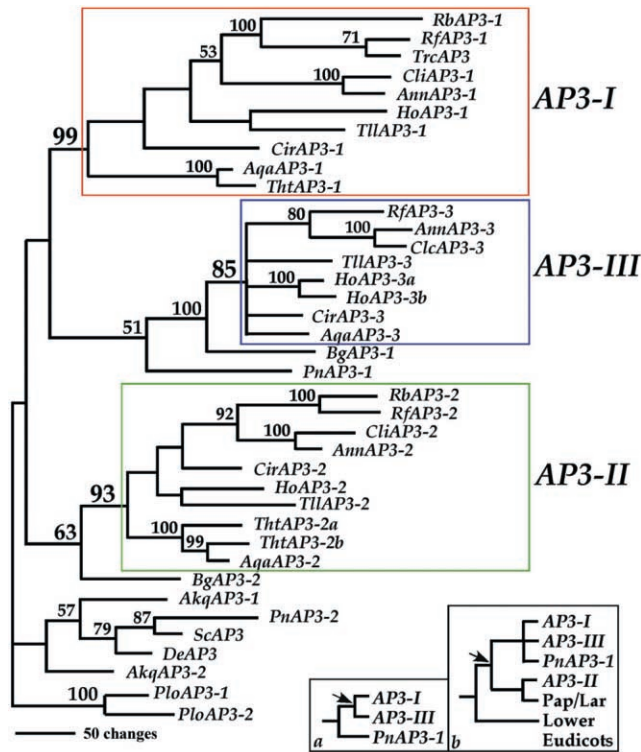

Fig. 4 Consensus tree of two equally parsimonious trees of 3225 steps. The numbers next to the nodes give bootstrap values from 1000 replicates. Major lineages are indicated by boxes. Insets *a* and *b*, Simplified topologies that minimize number of inferred gene duplication events, which are indicated by arrows (see text). Pap/Lar indicates the paleoAP3 homologs from the Papaverales and Lardizabalaceae.

nodes reflect relationships that are consistent with the known phylogeny of the family (Hoot 1995). More recent gene duplications have occurred in the AP3-II lineage of *Thalictrum/Aquilegia* and the AP3-III lineage of *Helleborus orientalis*. Although the phylogeny strongly indicates that a duplication in AP3-II occurred before the split of *Aquilegia* and *Thalictrum*, expression of an AP3-2b ortholog was not detected in *Aquilegia*. Genomic PCR and southern hybridization will be required to determine the genomic basis for this absence.

Phylogenetic Analysis of the PISTILLATA Lineage

Twenty new PI homologs were identified in the nine Ranunculaceae genera surveyed. Eight of these loci appeared to be heterozygous for distinct alleles, which varied from 94% to 99% identity throughout their length with few nonsynonymous differences. All of the predicted protein sequences conformed to the expected structure of PI homologs with clearly identifiable PI motifs (fig. 5). An alignment of the complete nucleotide coding sequences of all the Ranunculaceae genes, in addition to the PI homologs of *Berberis* and *Akebia*, was analyzed under maximum parsimony. This produced two most parsimonious trees of 1819 steps (consensus shown in fig. 6). In contrast to the AP3 data set, the PI paralogs appear to be the products of many recent duplication events. In all, this phylogeny indicates a minimum of 11 separate duplications in

the PI lineage within the Ranunculaceae. Some clearly occurred before the split of closely related genera such as *Ranunculus* and *Trautvetteria* or *Clematis* and *Anemone*. In the case of the *Ranunculus/Trautvetteria* duplications, a "full" complement of paralogs has only been characterized in *R. ficaria*, indicating that in *Ranunculus bulbosus* and *Trautvetteria* floral expression of certain PI paralogs may have been lost.

The relationships of the genera to one another have very little bootstrap support. Although each MP tree is highly incongruent with the known phylogenetic relationships of the genera, they are also in disagreement with one another (as indicated by the lack of resolution in the consensus tree). A tree that is consistent with the published generic relationships is only seven steps longer than the most parsimonious trees. This difference is not significant using either Templeton or Kishino-Hasegawa tests ($P = 0.16$ and 0.13 , respectively).

Analysis of Differential Expression in *Aquilegia* and *Clematis*

The floral phenotype of many taxa in the Ranunculaceae could be consistent with an expansion of B gene expression into the first whorl of the perianth. In order to investigate this possibility, gene-specific RT-PCR was performed in several species using RNA prepared from floral organs dissected from early through midstage buds. In *Aquilegia alpina*, these experiments revealed the presence of transcript from all three AP3 paralogs and PI in both whorls of the perianth, confirming that B gene expression is expanded into the petaloid sepals (fig. 7A).

In the cultivar *Aquilegia clematiflora*, the second-whorl or-

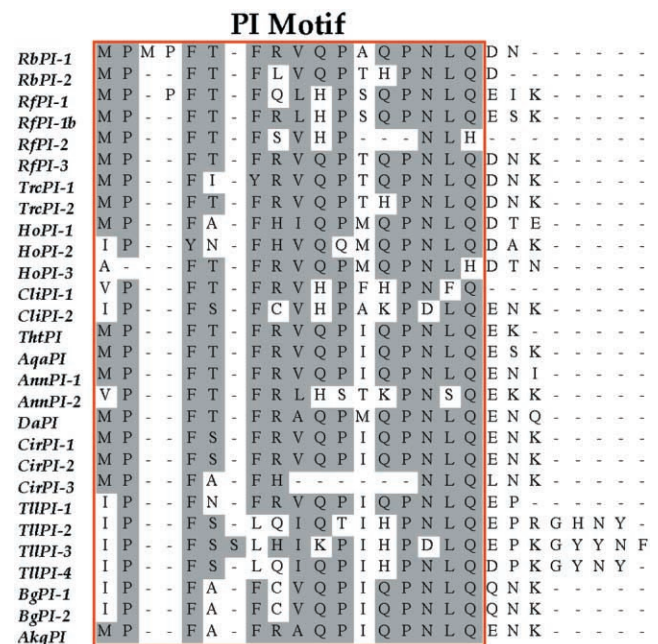

Fig. 5 Alignment of the C termini of predicted protein sequences from all identified PI homologs in the Ranunculaceae, *Berberis* and *Akebia*. The PI motif is indicated by a box. Residues in the PI motif that show chemical conservation are shaded.

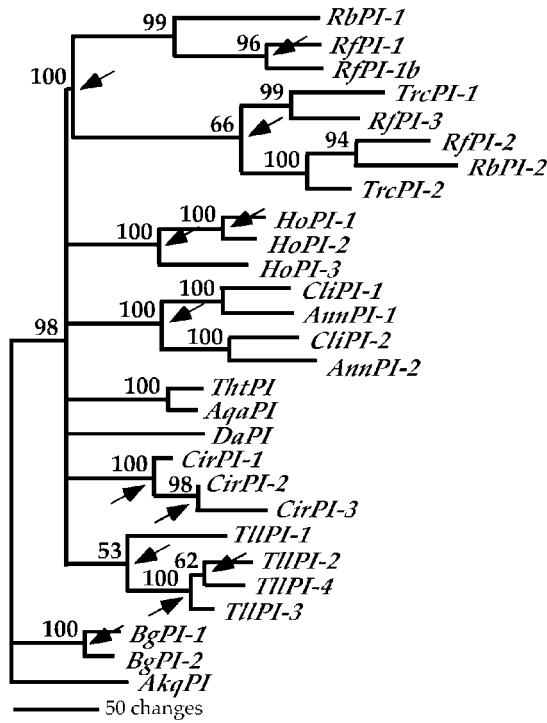

Fig. 6 Consensus tree of two equally parsimonious trees of 1819 steps. The numbers next to the nodes give bootstrap values. Nodes with less than 50% bootstrap support are collapsed. Arrows indicate inferred duplication events.

gans appear to be transformed into petaloid sepals (fig. 7B). These transformed organs have lost all the hallmarks of *Aquilegia* petals, including spurs and nectaries, and have the same shape and size as the first-whorl petaloid sepals. At the same floral stages as examined for *A. alpina*, the expression patterns of the *AqcAP3* and *AqcPI* loci are essentially identical to that in *A. alpina*, with the notable exception of the *AP3-III* ortholog (fig. 7B). Although *AqcAP3-3* transcript is detected in the stamens, expression appears to be completely absent from the perianth of *A. clematiflora*. The phenotype and expression profiles of *A. clematiflora* indicate that the expression of *AqcAP3-3* is not required to establish the petaloid phenotype of the sepals. Furthermore, in this cultivar it appears that the transcription of *AqcAP3-1*, *AqcAP3-2*, and *AqcPI* is not sufficient to determine the identity of second-whorl petals.

Clematis integrifolia is distinct from *Aquilegia* in that its perianth is made up of a single whorl of petaloid sepals. RT-PCR on the floral organs of *C. integrifolia* indicates that *CliAP3-2* and *CliPI-2* are expressed in both the perianth and stamens, but *CliAP3-1* and *CliPI-1* are detected only in stamens (fig. 8A). Members of the *Clematis* subgenus *Atragene* are characterized by a perianth more similar to that of *Aquilegia*, with petaloid sepals in the first whorl and morphologically distinct petals in the second. Analysis of *C. integrifolia* has not detected expression of an *AP3-III* ortholog, but we wished to confirm this observation and determine whether a representative of the *AP3-III* lineage might be expressed in the *Atragene* member *Clematis chiisanensis*. RT-PCR using a forward primer specific to the *AP3/PI* MADS domain with a reverse primer specific to *AP3-III* failed to amplify an *AP3-*

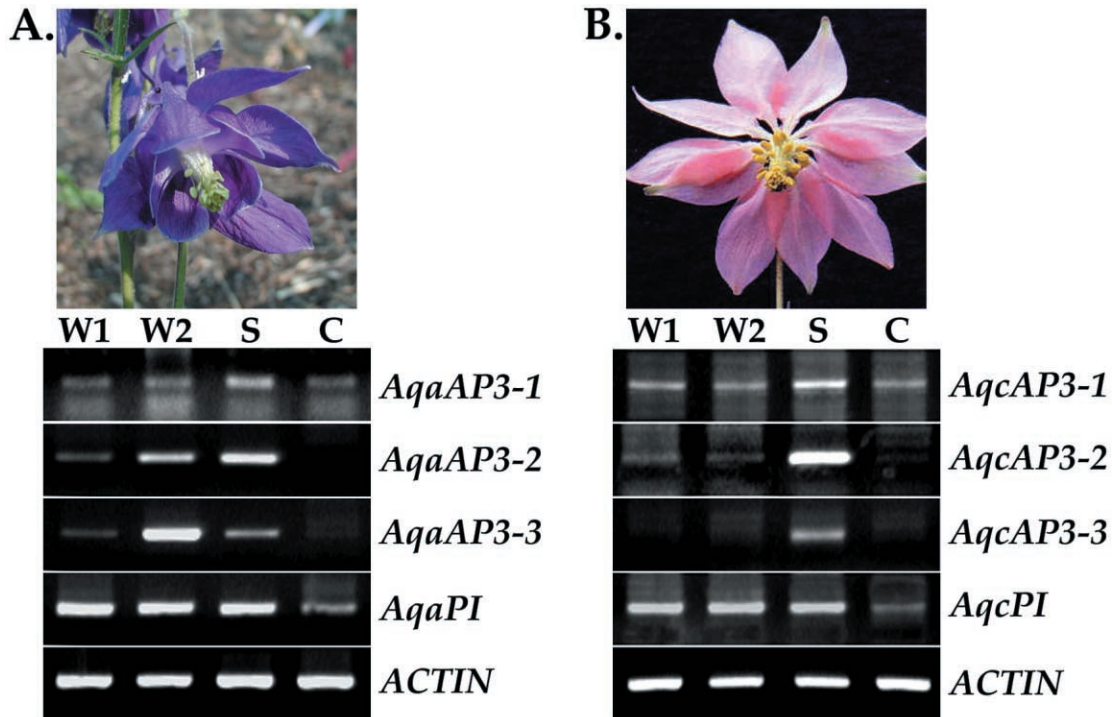

Fig. 7 Gene-specific RT-PCR reactions on RNA prepared from dissected early floral parts of comparable stages. Actin primers were used as a positive control. W1 = petaloid sepals; W2 = petals; S = stamens; C = carpels. A, *Aquilegia alpina*. B, *Aquilegia clematiflora*.

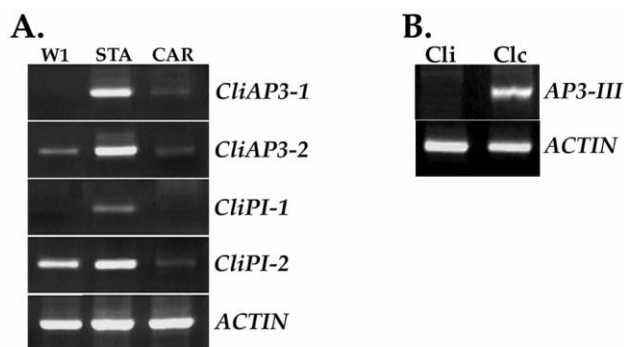

Fig. 8 A, Gene-specific RT-PCR reactions on RNA prepared from dissected early stage *Clematis integrifolia* floral parts. Actin primers were used as a positive control. W1 = petaloid sepals; STA = stamens; CAR = carpels. B, AP3-III-specific RT-PCR on RNA prepared from early through midstage flower buds of *C. integrifolia* and *Clematis chiisanensis*.

III ortholog in *C. integrifolia* but did produce a fragment of the expected size in *C. chiisanensis* (fig. 7B). This fragment was cloned and sequenced, confirming it as an AP3-III ortholog and allowing the identification of the corresponding cDNA (*ClcAP3-3*; figs. 3, 4).

Discussion

We have characterized a total of 43 new representatives of the AP3 and PI lineages from nine genera of the Ranunculaceae and seven homologs from one genus each of the Berberidaceae and Lardizabalaceae. Phylogenetic analyses have demonstrated that three separate AP3 lineages were present in the last common ancestor of the Ranunculaceae and, most likely, were established before the split of the Ranunculaceae and their sister family the Berberidaceae. It is difficult to assign a date to this divergence because of the lack of fossil material that can be clearly ascribed to the Ranunculaceae, but the broad distributions of both families indicates ancient origins (Tamura 1993; Hoot and Crane 1995). Furthermore, it is possible that at least one AP3 duplication predated the last common ancestor of the whole Ranunculid clade (ca. 120 mya; Hoot and Crane 1995; Magallon et al. 1999). In contrast, the paralogous PI lineage members appear to be the products of numerous, relatively recent duplications, which in some cases predate the split of sister genera.

It is notable that we have found little evidence for genome duplication events. The only species in the study for which ploidy information is available are *Aquilegia alpina*, which is a diploid (Bennett et al. 1982), and *Ranunculus ficaria*, which has been reported as both a diploid and a tetraploid (Bennett and Smith 1976). The one potential case indicated by our data is *Trollius laxus*, in which two apparent alleles were detected for every locus (AP3 and PI), raising the possibility that this species is a recent tetraploid.

AP3 Paralogs May Have Contributed to the Diversification of Floral Morphology in the Ranunculaceae

The “sliding-boundary” model discussed above provides a straightforward genetic mechanism for transition between an entirely petaloid perianth and a bipartite perianth that is differentiated into leaflike sepals and petals. In *Arabidopsis*, the expansion of B gene expression into first-whorl primordia results in the transformation of sepals into almost exact copies of second-whorl petals (Krizek and Meyerowitz 1996). Examples of entirely petaloid perianths that could fit this model include that of *Clermontia* (Di Laurenzio et al. 1998). A simple expansion of the B gene expression does not account for the production of morphologically distinct petaloid organs in separate whorls, however. In *Antirrhinum*, there is morphological differentiation of petals within a whorl, an effect achieved through the additive functions of the petal and dorsal/ventral identity programs (Luo et al. 1996). The situation in the Ranunculaceae is distinct from this case as well. The flowers of the Ranunculaceae are typically actinomorphic, with two whorls of petaloid organs that are identical within each whorl but differ between whorls in a consistent manner. These differences include primordium shape and position, vascular pattern, presence of nectaries, and aspects of final morphology (Tamura 1965). This evidence indicates that the presence of two types of petaloid organs in the same flower is not due to gradients of gene activity or other types of imprecision in the floral organ identity program. Instead, it appears that there are two distinct petal identity programs functioning in many genera of this family.

Assuming that the common ancestor of the Ranunculaceae expressed a basic version of the ABC program, we can imagine several possible models for how two petal identity programs might have been derived (table 2). First, the ABC program could be essentially unchanged, with the petaloid characteristics of the first-whorl organs due to modification of the sepal identity program downstream of A function (Bowman 1997). Our finding that B gene expression is present in the first-whorl organs indicates that this is probably not the case. Given the fact that transcription of B-class genes is not always indicative of the presence of stable protein (Jack et al. 1994; Tzeng and Yang 2001), however, it will be important to confirm the presence of AP3 and PI proteins in first-whorl organs. Another model that has been proposed is that the second-whorl petals are determined by an A+B+C code that is the result of an incursion of A function into the outer stamen primordia (Erbar et al. 1998). This model is based on the strong staminoid characteristics of many petals in the family. A difficult aspect of this hypothesis is that A and C functions are typically thought to be mutually exclusive (Coen and Meyerowitz 1991). However, it has been shown in *Arabidopsis* that the ability of AG to repress AP1 expression is concentration dependent such that low amounts of AG protein can provide organ identity but are not sufficient to repress AP1 (Mizukami and Ma 1995). We have not been able to detect the expression of AG homologs in second-whorl organs (E. M. Kramer, unpublished data), but we have not yet examined genera such as *Xanthorhiza*, which have strongly staminoid petals. A third possibility is that the second-whorl petals may express B-group

Table 2

Possible Modifications of the ABC Program		
Model	Whorl 1	Whorl 2
1	A	A+B
2	A+B	A+B+C
3	A+B	B
4	A+B'	A+B''

Note. Four possible genetic models for the determination of the two distinct types of petaloid organs found in the Ranunculaceae.

genes alone. In *Arabidopsis*, floral organs that express only B-function genes have a phenotype intermediate between that of petals and stamens (Bowman et al. 1991; Krizek and Meyerowitz 1996). Testing this model will require the characterization of A group gene homologs, which is currently underway.

The last model we would like to consider is that duplications in the AP3 and/or PI lineages may have contributed to the evolution of separate petal identity programs. Differential expression or functional specialization of particular paralogs could provide the information needed to distinguish between types of petaloid organs. The best candidates for such a role appear to be the representatives of the AP3-III lineage. Our RT-PCR approach detected expression of AP3-III orthologs only in flowers that possess petals (fig. 9), with the one exception of *Anemone nemerosa*. Interestingly, *AnnAP3-3* appears to have a rather divergent paleoAP3 motif, which could reflect some divergence in function. The gene-specific RT-PCR experiments have revealed further associations between the presence of petals and the expression of AP3-III orthologs. In *A. alpina*, *AqaAP3-3* is strongly expressed in the second-whorl petals, but transcript is not detected in the mutant perianth organs of *Aquilegia clematiflora*. Similarly, we have found that while *Clematis integrifolia* lacks petals and appears to lack AP3-III expression, *Clematis chiisanensis* has petals and expresses an AP3-III ortholog. These results are merely correlative, but they do allow us to hypothesize that the orthologs of AP3-III may be involved in distinguishing between petaloid sepals in the first whorl and morphologically distinct petals in the second. Although it has been proposed that the petals of the Ranunculaceae are the products of many independent derivations from stamens, the fact that the AP3-III lineage predates the diversification of the family raises the possibility that its role may have evolved early on and may represent a type of underlying synapomorphy for the family. Alternatively, the mere existence of the paralogous AP3 lineages could have created a predisposition toward the repeated evolution of distinct petal identity programs.

Distinct Patterns of Gene Duplication and Paralog Maintenance in the AP3 and PI Lineages

Although a similar number of AP3 and PI homologs have been identified in the nine genera surveyed, the phylogenetic analyses indicate clear differences in the timing of the duplications that produced these loci (fig. 9). There is no evidence that gene-conversion events have drastically reduced variation among PI paralogs within particular genera, thereby eliminating the signatures of duplications in the distant past. It also

seems very unlikely that rates of gene duplication have varied between the AP3 and PI lineages over the course of Ranunculid evolution. We have evidence for only two duplications in the AP3 lineage within the family, and ongoing analyses of the AG lineage show a similarly small number of recent duplications (E. M. Kramer and V. S. Di Stilio, unpublished data). In addition, phylogenetic analyses using nuclear markers have not detected any evidence of genome duplications in these taxa (Hoot 1995; Ro et al. 1997). These findings appear to argue against multiple, recent genome-wide phenomena. Our data, instead, indicate that the two lineages have differed in their tendency to maintain the floral expression of AP3 and PI paralogs. During the “early” phase (ca. 70–120 mya), at least two duplications occurred in the AP3 lineage, giving rise to the paralogous AP3-I, -II, and -III lineages. These lineages were retained and acquired clear synapomorphic differences before the diversification of the Ranunculaceae, as indicated by the high bootstrap support for each lineage. At the same time, duplications were most likely occurring in the PI lineage as well, but these paralogs were not maintained, or, at least, did not remain florally expressed. Conversely, within the more recent radiation of the Ranunculaceae, PI paralogs appear to have been retained at a higher frequency than those resulting from further duplications in AP3.

What forces might have increased the likelihood that floral expression of PI paralogs would be maintained? The key to addressing this question may lie in the nature of the regulation and biochemical functions of AP3 and PI. In the core eudicots, every aspect of the biology of euAP3 and PI genes appears to be interdependent. Their gene products function as obligate heterodimers (Schwarz-Sommer et al. 1992; Riechmann et al. 1996a), an interaction which is necessary to maintain the stability of the proteins and to promote their nuclear localization (Jack et al. 1994; McGonigle et al. 1996; Jenik and Irish 2000). In addition, they autoregulate their own expression, both directly and indirectly (Zachgo et al. 1995; Hill et al. 1998; Honma and Goto 2000), and have equivalent mutant phe-

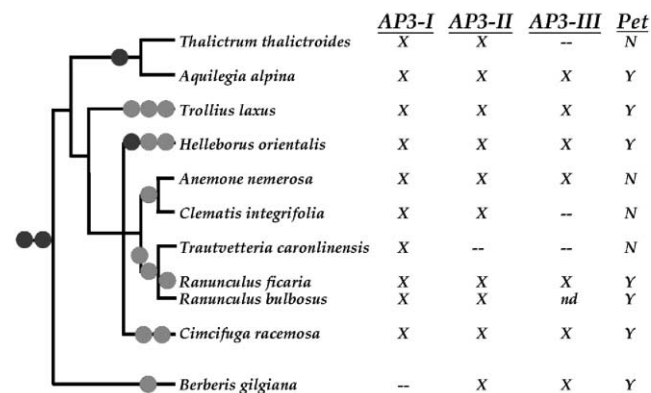

Fig. 9 Phylogenetic relationships of taxa surveyed in this study, based on Hoot 1995. The inferred AP3 and PI duplication events are indicated by black and gray dots, respectively. Chart to the right indicates floral expression of each paralogous AP3 lineage (X = expression detected; two dashes = no expression detected) and whether or not the species possesses petals or staminodia in the second whorl (Hoot 1995; Tamura 1965). nd = not determined.

notypes (Bowman et al. 1989; Trobner et al. 1992). For these reasons, it is impossible to genetically dissect euAP3 and PI function. Outside the core eudicots, these interactions may not be absolutely conserved (Kramer and Irish 2000), but even in *Lilium* where the PI homolog can bind DNA as a homodimer, the PI still retains its ability to heterodimerize with AP3 proteins (Tzeng and Yang 2001; Winter et al. 2002).

The interdependency of AP3 and PI function raises the possibility that the two lineages may be prone to patterns of coevolution (Fryxell 1996). Unlike other cases of coevolution, the increased retention of PI paralogs does not appear to have been an immediate response to duplications in the AP3 lineage. Rather, we suggest that it may have been the more recent functional specialization of AP3 paralogs in conjunction with the evolution of novel petal identity programs that has favored the maintenance of PI paralogs. Under this model, the regulation and specificity of PI paralogs may be evolving to promote interaction with particular AP3 paralogs. We can make several predictions based on this hypothesis. First, it would be expected that the expression patterns of certain AP3 and PI paralogs may be coordinated with each other, while expression may differ between paralogs of the same lineage, as is observed in *C. integrifolia*. This would necessitate cis-differences in the promoters of uncoordinated paralogs, such as *ClPI-1* and *ClPI-2*, which may be discernable by analyses of promoter sequences. In addition, dimerization affinities may differ among AP3 and PI paralogs such that particular PI proteins

have greater affinity for specific AP3 gene products. This type of specialization would not be expected to result in a significant degree of genewide positive selection but would instead most likely affect isolated residues in the I domain (Riechmann et al. 1996a). What is especially interesting about the Ranunculaceae is that while the specialization of AP3 paralogs may have occurred once before the diversification of the family, it is clear that any specialization of PI paralogs has occurred many times independently, allowing us to test these hypotheses in what essentially represent evolutionary replicates. The results of these further studies will serve to clarify the role of AP3 and PI paralogs in the establishment of separate petal identities in the Ranunculaceae and, more broadly, help us to understand how the ABC program may have been modified over the course of angiosperm evolution to produce the diversity of floral morphology.

Acknowledgments

We thank Daniel Fulop, Lena Hileman, and M. Alejandra Jaramillo for assistance with the phylogenetic analyses and Eric Wehrenberg-Klee for help with screening of clones. We would also like to thank the entire Kramer lab for helpful discussions and three anonymous reviewers for comments on the manuscript. This work was supported by funding from the Harvard Milton Fund to E. M. Kramer and the Mercer Fellowship of the Arnold Arboretum to V. S. Di Stilio.

Literature Cited

- Albert VA, MHG Gustafsson, L Di Laurenzio 1998 Ontogenetic systematics, molecular developmental genetics, and the angiosperm petal. Pages 349–374 in D Soltis, P Soltis, JJ Doyle, eds. Molecular systematics of plants. Vol 2. Chapman & Hall, New York.
- Alvarez-Buylla ER, S Pelaz, SJ Liljegren, SE Gold, C Burgeff, GS Ditta, L Ribas de Pouplana, et al 2000 An ancestral MADS-box gene duplication occurred before the divergence of plants and animals. *Proc Natl Acad Sci USA* 97:5328–5333.
- Ambrose BA, DR Lerner, P Ciceri, CM Padilla, MF Yanofsky, RJ Schmidt 2000 Molecular and genetic analyses of the *Silky1* gene reveal conservation in floral organ specification between eudicots and monocots. *Mol Cell* 5:569–579.
- Angenent GC, J Franken, M Busscher, A Van Dijken, JL Van Went, HJM Dons, AJ Van Tunen 1995 A novel class of MADS box genes is involved in ovule development in *Petunia*. *Plant Cell* 7: 1569–1582.
- Becker A, K-U Winter, B Meyer, H Saedler, G Theissen 2000 MADS-box gene diversity in seed plants 300 million years ago. *Mol Biol Evol* 17:1425–1434.
- Bennett MD, JB Smith 1976 Nuclear DNA amounts in angiosperms. *Philos Trans R Soc Lond B Biol Sci* 274:227–274.
- Bennett MD, JB Smith, JS Heslop-Harrison 1982 Nuclear-DNA amounts in angiosperms. *Proc R Soc Lond B Biol Sci* 216:179–199.
- Bierhorst DW 1971 Morphology of vascular plants. Macmillan, New York.
- Bowman JL 1997 Evolutionary conservation of angiosperm flower development at the molecular and genetic levels. *J Biosci* 22: 515–527.
- Bowman JL, DR Smyth, EM Meyerowitz 1989 Genes directing flower development in *Arabidopsis*. *Plant Cell* 1:37–52.
- 1991 Genetic interactions among floral homeotic genes of *Arabidopsis*. *Development* 112:1–20.
- Carpenter R, ES Coen 1990 Floral homeotic mutations produced by transposon-mutagenesis in *Antirrhinum majus*. *Genes Dev* 4: 1483–1493.
- Coen ES, EM Meyerowitz 1991 The war of the whorls: genetic interactions controlling flower development. *Nature* 353:31–37.
- Colombo L, J Franken, E Koetje, J Van Went, HJM Dons, GC Angenent, AJ Van Tunen 1995 The petunia MADS box gene FBP11 determines ovule identity. *Plant Cell* 7:1859–1868.
- Di Laurenzio L, B Johansen, VA Albert 1998 The homeotic double-corolla phenotype in Hawaiian *Clermontia* (Lobelioideae: Campanulaceae) is caused by overexpression of a B-function MADS box gene. *Am J Bot* 85:124.
- Eames AJ 1961 Morphology of the angiosperms. McGraw-Hill, New York.
- Egea-Cortines M, H Saedler, H Sommer 1999 Ternary complex formation between the MADS-box proteins SQUAMOSA, DEFICIENS and GLOBOSA is involved in the control of floral architecture in *Antirrhinum majus*. *EMBO (Eur Mol Biol Org) J* 18:5370–5379.
- Erbar C, S Kusma, P Leins 1998 Development and interpretation of nectary organs in Ranunculaceae. *Flora* 194:317–332.
- Fryxell KJ 1996 The coevolution of gene family trees. *Trends Genet* 12:364–369.
- Gutierrez-Cortines ME, B Davies 2000 Beyond the ABCs: ternary complex formation in the control of floral organ identity. *Trends Plant Sci* 5:471–476.
- Hill T, CD Day, SC Zondlo, AG Thackeray, VF Irish 1998 Discrete spatial and temporal cis-acting elements regulate transcription of the *Arabidopsis* floral homeotic gene *APETALA3*. *Development* 125:1711–1721.
- Hodges SA, ML Arnold 1994 Columbines: a geographically widespread species flock. *Proc Natl Acad Sci USA* 91:5129–5132.
- Honma T, K Goto 2000 The *Arabidopsis* floral homeotic gene *PIS-*

- TILLATA* is regulated by discrete cis-elements responsive to induction and maintenance signals. *Development* 127:2021–2030.
- 2001 Complexes of MADS-box proteins are sufficient to convert leaves into floral organs. *Nature* 409:525–529.
- Hoot S, PR Crane 1995 Inter-familial relationships in the Ranunculaceae based on molecular systematics. *Plant Syst Evol Suppl* 9: 119–131.
- Hoot SB 1995 Phylogeny of the Ranunculaceae based on preliminary atpB, rbcL and 18S nuclear ribosomal DNA sequence data. *Plant Syst Evol Suppl* 9:241–251.
- Jack T, GL Fox, EM Meyerowitz 1994 *Arabidopsis* homeotic gene *APETALA3* ectopic expression: transcriptional and posttranscriptional regulation determine floral organ identity. *Cell* 76:703–716.
- Jenik PD, VF Irish 2000 The *Arabidopsis* floral homeotic gene *APETALA3* differentially regulates intercellular signaling required for petal and stamen development. *Development* 128:13–23.
- Johansen B, LB Pederson, M Skipper, S Frederiksen 2002 MADS-box gene evolution: structure and transcription patterns. *Mol Phylogenet Evol* 23:458–480.
- Kang H-G, J-S Jeon, S Lee, G An 1998 Identification of class B and class C floral organ identity genes from rice plants. *Plant Mol Biol* 38:1021–1029.
- Kishino H, M Hasegawa 1989 Evaluation of the maximum likelihood estimate of the evolutionary tree topologies from DNA sequence data, and the branching order in Hominoidea. *J Mol Evol* 29: 170–179.
- Kosuge K 1994 Petal evolution in Ranunculaceae. *Plant Syst Evol Suppl* 8:185–191.
- Kosuge K, M Tamura 1989 Ontogenic studies on petals of the Ranunculaceae. *J Jpn Bot* 64:65–74.
- Kramer EM, RL Dorit, VF Irish 1998 Molecular evolution of genes controlling petal and stamen development: duplication and divergence within the *APETALA3* and *PISTILLATA* MADS-box gene lineages. *Genetics* 149:765–783.
- Kramer EM, VF Irish 1999 Evolution of genetic mechanisms controlling petal development. *Nature* 399:144–148.
- 2000 Evolution of the petal and stamen developmental programs: evidence from comparative studies of the lower eudicots and basal angiosperms. *Int J Plant Sci* 161:S29–S40.
- Krizek BA, EM Meyerowitz 1996 The *Arabidopsis* homeotic genes *APETALA3* and *PISTILLATA* are sufficient to provide the B class organ identity function. *Development* 122:11–22.
- Kyoizuka J, T Kobayashi, M Morita, K Shimamoto 2000 Spatially and temporally regulated expression of rice MADS box genes with similarity to *Arabidopsis* class A, B and C genes. *Plant Cell Physiol* 41:710–718.
- Luo D, R Carpenter, C Vincent, L Copsey, E Coen 1996 Origin of floral asymmetry in *Antirrhinum*. *Nature* 383:794–799.
- Ma H, C dePamphilis 2000 The ABCs of floral evolution. *Cell* 101: 5–8.
- Magallon S, PR Crane, PS Herendeen 1999 Phylogenetic pattern, diversity, and diversification of eudicots. *Ann Mo Bot Gard* 86: 297–372.
- McGonigle B, K Bouhidel, VF Irish 1996 Nuclear localization of the *Arabidopsis* *APETALA3* and *PISTILLATA* homeotic gene products depends on their simultaneous expression. *Genes Dev* 10: 1812–1821.
- Mena M, BA Ambrose, RB Meeley, SP Briggs, MF Yanofsky, RJ Schmidt 1996 Diversification of C-function activity in maize flower development. *Science* 274:1537–1540.
- Mizukami Y, H Ma 1992 Ectopic expression of the floral homeotic gene *agamous* in transgenic *Arabidopsis* plants alters floral organ identity. *Cell* 71:119–131.
- 1995 Separation of AG function in floral meristem determination from that in reproductive organ identity by expressing antisense AG RNA. *Plant Mol Biol* 28:767–784.
- Munz PA 1946 *Aquilegia*: the cultivated and wild columbines. *Gentes Herb* 7:1–150.
- Ohno S 1970 Evolution by gene duplication. Springer, Heidelberg.
- Otto SP, P Yong 2002 The evolution of gene duplicates. *Adv Genet* 46:451–483.
- Pelaz S, GS Ditta, E Baumann, E Wisman, M Yanofsky 2000 B and C floral organ identity functions require SEPALLATA MADS-box genes. *Nature* 405:200–203.
- Riechmann JL, BA Krizek, EM Meyerowitz 1996a Dimerization specificity of *Arabidopsis* MADS domain homeotic proteins APETALA1, APETALA3, PISTILLATA, and AGAMOUS. *Proc Natl Acad Sci USA* 93:4793–4798.
- Riechmann JL, M Wang, EM Meyerowitz 1996b DNA-binding properties of *Arabidopsis* MADS domain homeotic proteins APETALA1, APETALA3, PISTILLATA and AGAMOUS. *Nucleic Acids Res* 24: 3134–3141.
- Ro KE, CS Keener, BA McPherson 1997 Molecular phylogenetic study of the Ranunculaceae: utility of the nuclear 26S ribosomal DNA in inferring intrafamilial relationships. *Mol Phylogenet Evol* 8:117–127.
- Schwarz-Sommer Z, I Hue, P Huijser, PJ Flor, R Hansen, F Tetens, W-E Lonnig, et al 1992 Characterization of the *Antirrhinum* floral homeotic MADS-box gene *deficiens*: evidence for DNA binding and autoregulation of its persistent expression throughout flower development. *EMBO (Eur Mol Biol Org) J* 11:251–263.
- Shore P, AD Sharrocks 1995 The MADS-box family of transcription factors. *Eur J Biochem* 229:1–13.
- Swofford DL 2001 PAUP* 4.0b1: phylogenetic analysis using parsimony (*and other methods). Sinauer, Sunderland, Mass.
- Takhtajan A 1991 Evolutionary trends in flowering plants. Columbia University Press, New York.
- Tamura M 1965 Morphology, ecology, and phylogeny of the Ranunculaceae. IV. *Sci Rep Osaka Univ* 14:53–71.
- 1981 Morphology of *Coptis japonica* and its meaning in phylogeny. *Bot Mag Tokyo* 94:165–176.
- 1993 Ranunculaceae. Pages 563–583 in K Kubitzki, JG Rohwer, V Bittrich, eds. The families and genera of vascular plants. 2. Flowering plants. Dicotyledons. Magnoliid, hamamelid and Caryophyllid families. Vol 2. Springer, Berlin.
- Templeton AR 1983 Phylogenetic inference from restriction endonuclease cleavage site maps with particular reference to the evolution of humans and the apes. *Evolution* 37:221–244.
- Theissen G, A Becker, A Di Rosa, A Kanno, JT Kim, T Munster, K-U Winter, et al 2000 A short history of MADS-box genes in plants. *Plant Mol Biol* 42:115–149.
- Trobner W, L Ramirez, P Motte, I Hue, P Huijser, WE Lonnig, H Saedler, et al 1992 Globosa: a homeotic gene which interacts with *deficiens* in the control of *Antirrhinum* floral organogenesis. *EMBO (Eur Mol Biol Org) J* 11:4693–4704.
- Tzeng TY, CH Yang 2001 A MADS box gene from lily (*Lilium longiflorum*) is sufficient to generate dominant negative mutation by interacting with *PISTILLATA* (*PI*) in *Arabidopsis thaliana*. *Plant Cell Physiol* 42:1156–1168.
- Winter KU, C Weiser, K Kaufmann, A Bohne, C Kirchner, A Kanno, H Saedler, et al 2002 Evolution of class B floral homeotic proteins: obligate heterodimerization originated from homodimerization. *Mol Biol Evol* 19:587–596.
- Zachgo S, E de Andrade Silva, P Motte, W Trobner, H Saedler, Z Schwarz-Sommer 1995 Functional analysis of the *Antirrhinum* floral homeotic *Deficiens* gene in vivo and in vitro by using a temperature-sensitive mutant. *Development* 121:2861–2875.